

Assembly Instructions for PMA-6031 Tilt Wall Mount

Thank you for choosing our Tilt Wall Mount. This product is designed to mount flat panel televisions to a vertical wall. The distance from the back of TV to wall is only 3 inches. This mount allows you to tilt your television up and down to 15° without the use of tools.

Safety Warning: If you do not understand these directions, or have any doubts about the safety of the installation, please call a qualified contractor. Check carefully to make sure there are no missing or defective parts. Never use defective parts. Improper installation may cause damage or serious injury. Do not use this product for any purpose that is not explicitly specified in this manual. We can not be liable for damage or injury caused by incorrect mounting, incorrect assembly, or incorrect use.

Note: The supplied wall mounting hardware is not for steel stud walls or old cinder block walls. If you are uncertain about the nature of your wall, consult an installation contractor. We makes every effort to assure all necessary television mounting hardware is included. If the hardware you need is not included please consult your local hardware store.

Required Tools: 3/16 drill bit, 1/2" Masonry Bit for brick concrete or concrete block installations, wrench or socket set, Phillips screw driver.

Supplied Parts

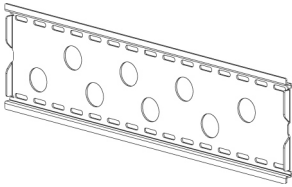

(1)Wall Plate-a

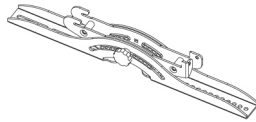

(1)Left Monitor Bracket-b

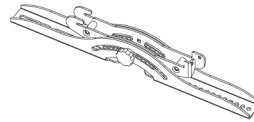

(1)Right Monitor Bracket-c



(1)Allen Key-d



(4)M4x12 Bolt-e

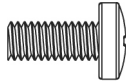

(4)M5x12 Bolt-f

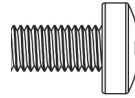

(4)M6x12 Bolt-g

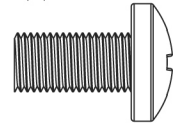

(4)M8x16 Bolt-h

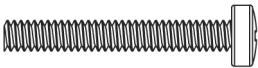

(4)M4x30 Bolt-i

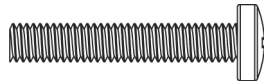

(4)M5x30 Bolt-j

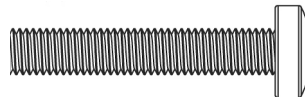

(4)M6x35 Bolt-k

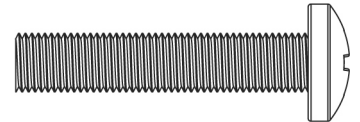

(4)M8x40 Bolt-l



(4)M4 Lock Washer-m



(4)M5 Lock Washer-n



(4)M6 Lock Washer-o

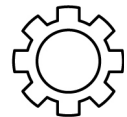

(4)M8 Lock Washer-p

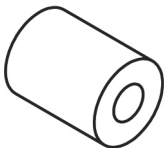

(4)M4/M5 Space-q

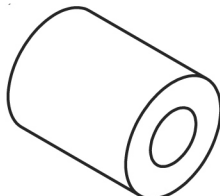

(4)M6/M8 Space-r

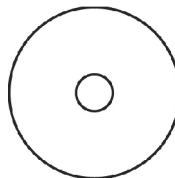

(8)M4/M5 Washer-s

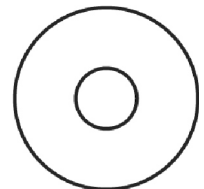

(4)M6/M8 Washer-t



(2)Safety Bolt-u



(6)Lag Bolt-v

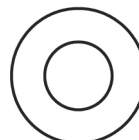

(6)Lag Bolt Washer-w

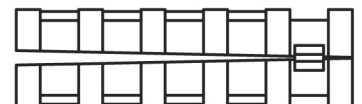

(6)Concrete Anchor-x

Step 1: Mounting Monitor Brackets to a television with a Flat Back

First, determine the diameter of the Bolt(e,f,g,h) your TV requires by hand threading them into the threaded insert on the back of the TV. If you encounter and resistance, pls stop immediately! Once you have determined the correct diameter, see the appropriate diagram below. You will thread the Bolt through the appropriate Lock Washer(m,n,o,p), a Washer(s,t), the Monitor Bracket(c), and finally into the TV. Make sure the Monitor Brackets are vertically centered and level with each other.

M4 Diameter Bolt

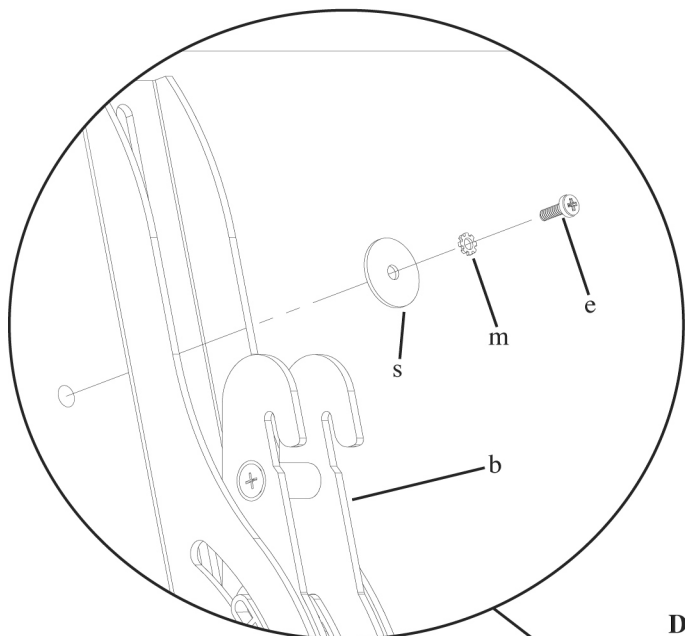

M6 Diameter Bolt

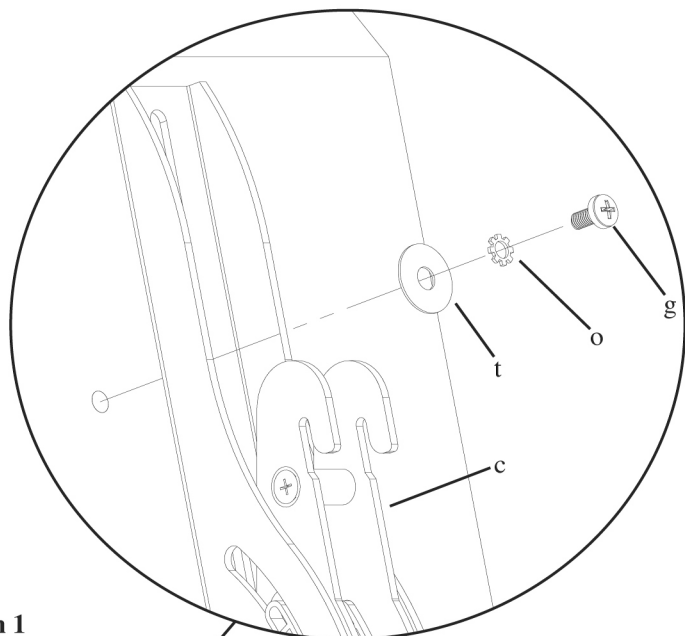
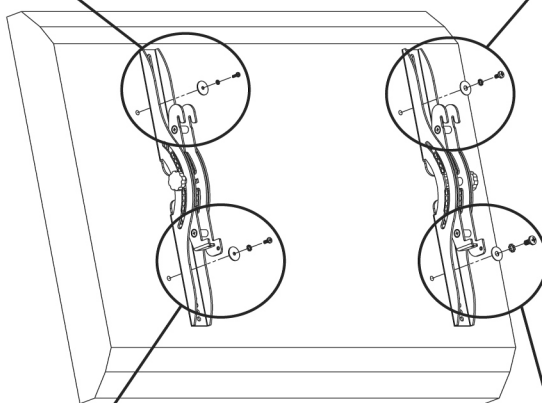
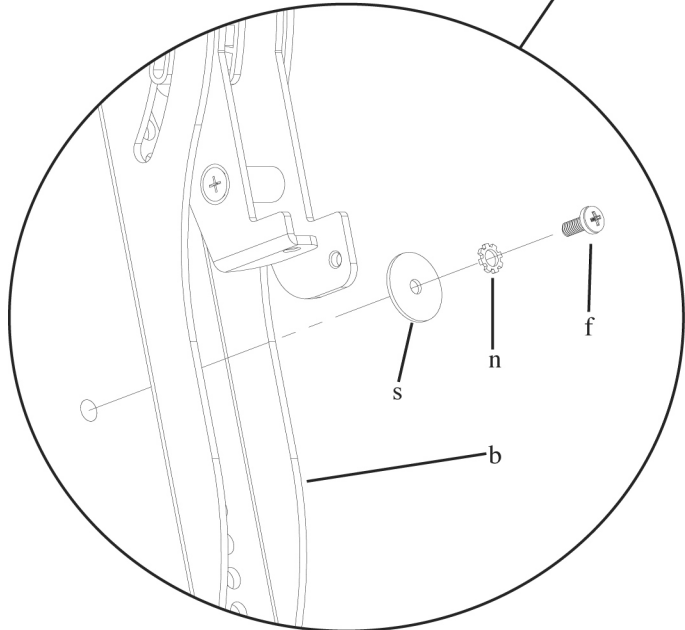

Diagram 1



M5 Diameter Bolt



M8 Diameter Bolt

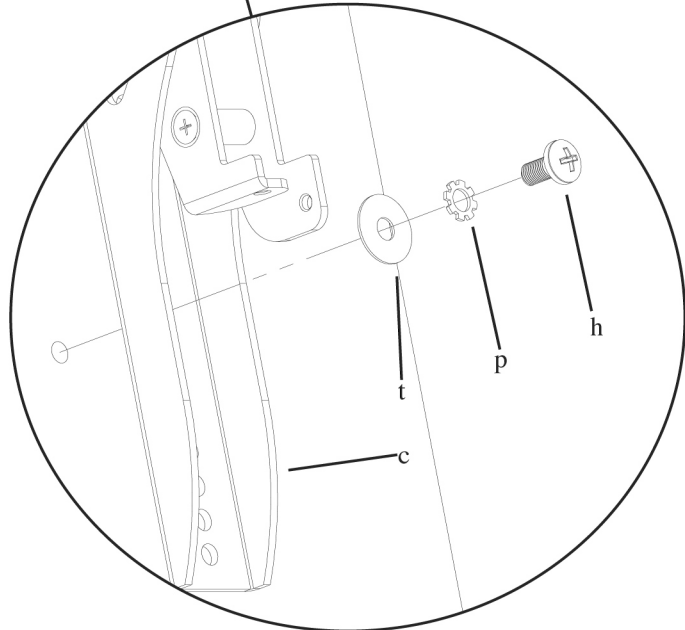

Step 2: Mounting Monitor Brackets to a television with a curved back, recessed threaded inserts or any other obstruction

First, determine the diameter of the Bolt(i,j,k,l) your TV requires by hand threading them into the threaded insert on the back of the TV. If you encounter and resistance, pls stop immediately! Once you have determined the correct diameter, see the appropriate diagram below. You will thread the Bolt through the appropriate Lock Washer(m,n,o,p), a Washer(s,t), the Monitor Bracket(c), a spacer(q,r) and finally into the TV. For the M4 or M5 diameter bolt, you will need another M4/M5 Washer between the Monitor Bracket and the Spacer. Make sure the Monitor Brackets are vertically centered and level with each other.

M4 Diameter Bolt

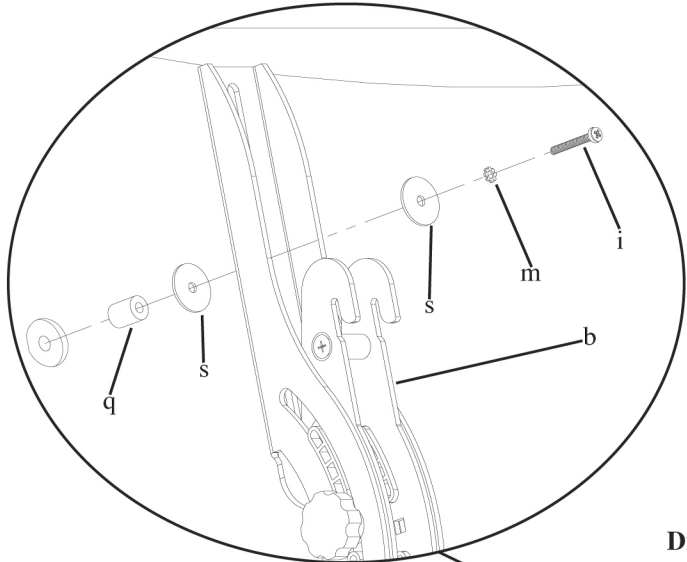

M6 Diameter Bolt

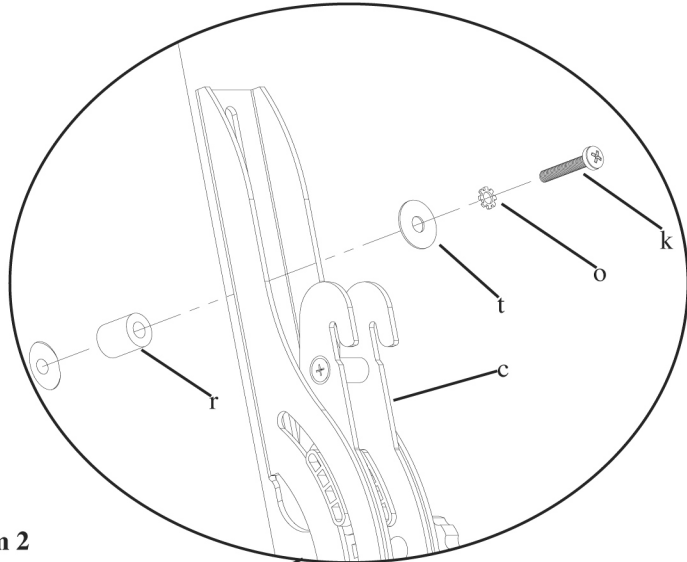
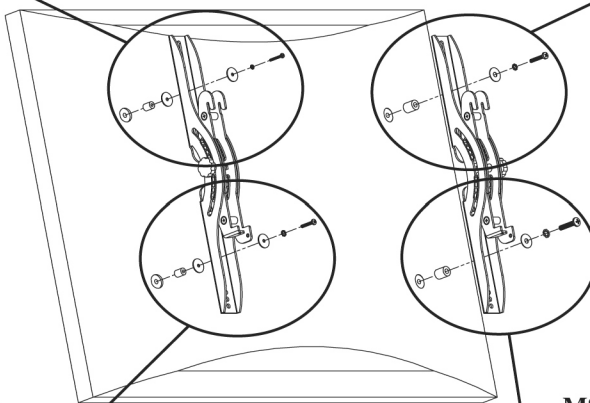
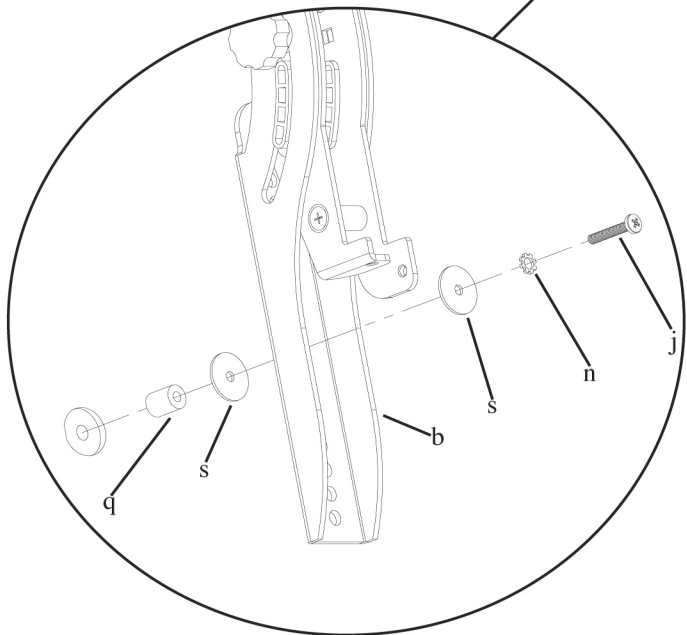

Diagram 2



M5 Diameter Bolt



M8 Diameter Bolt

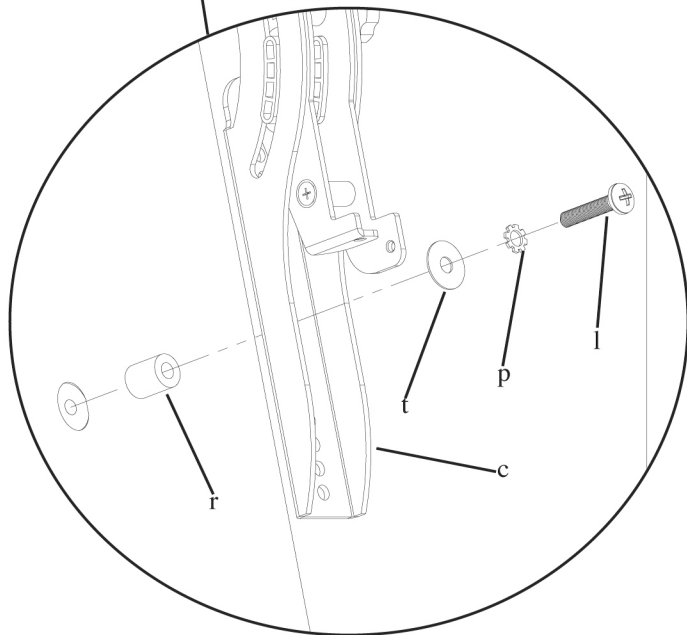

Step 3: Mounting the Wall Plate: Wood Stud, Brick, Solid Concrete, and Concrete Block mounting options are provided

Wood Stud mounting:

The Wall Plate(a) **must be mounted to two wood studs at least 16" apart**. Use a high quality stud sensor to locate two adjacent studs. It is a good idea to verify where the studs are located with an awl or thin nail shown in Diagram 3a. Pre-drill a 2.5" deep hole at the desired height in each stud using a 3/16" drill bit. Make sure these holes are in the center area of the studs and level with each other. Use the Wall Plate as a template to mark the location of the second hole in each stud. Drill 2.5" deep holes using the 3/16" drill bit in the marked locations. Attach the Wall Plate to the wall using the 4pcs 1/4 x 2.5" Lag Bolts(v) and 4pcs Lag Bolt Washers(w). Make sure the Wall Plate is oriented so the flat surface in the center of the plate is against the wall and that a set of Lag Bolts is on each side of the two large holes in the center as shown in Diagram 3b.

Brick, Solid Concrete and Concrete Block mounting:

Use the Wall Plate(a) as a template to mark 6 hole locations on the wall. The outer holes must fall to the left and right of the two holes in the middle of the plate. Three in the top row of slots and three more in the bottom row. Make sure there holes are level and there is at least 6" distance between any two holes. Pre-Drill these holes with a 1/2" masonry bit to at least 2.5" in depth. Insert a Concrete Anchor(x) into each of these holes. Make sure the anchor is seated completely flush with the concrete surface even if there is a layer of drywall or other material in front. Attach the Wall Plate to the wall using 6 Lag Bolts(v) and 6 Lag Bolt Washers(w).

Diagram 3a

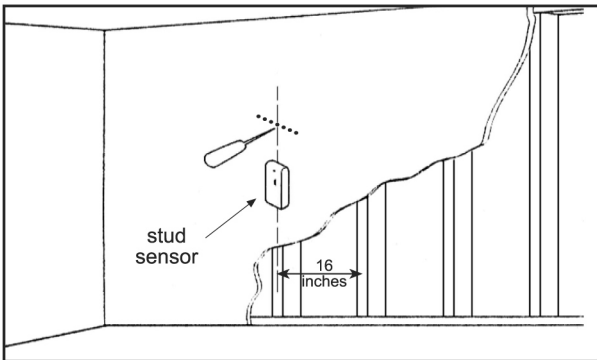
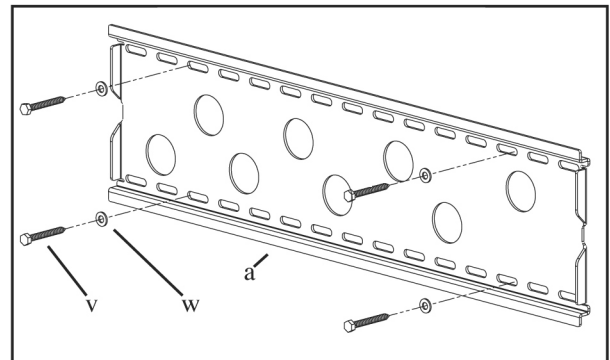

Diagram 3b



Step 4: Attaching Monitor to Wall Plate and adding Safety Bolts

Warning: Some televisions may require 2 people to lift! We are not responsible for personal injury or product damage.

First hook the Monitor Brackets(b,c) over the top of the wall Plate(a), then let the bottom of the Monitor Brackets rotated to the bottom of the Wall Plate as shown in the diagram 4a. Insert the Safety Bolts(u) into the threaded holes in the bottom of the Monitor Brackets. Use the Allen Key(d) to tighten the bolts. Then the Monitor Bracket will sit behind the bottom tab on the Wall Plate as shown in the Details View of Diagram 4b.

Diagram 4a

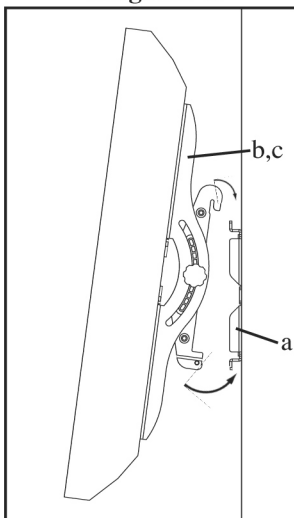

Diagram 4b

